

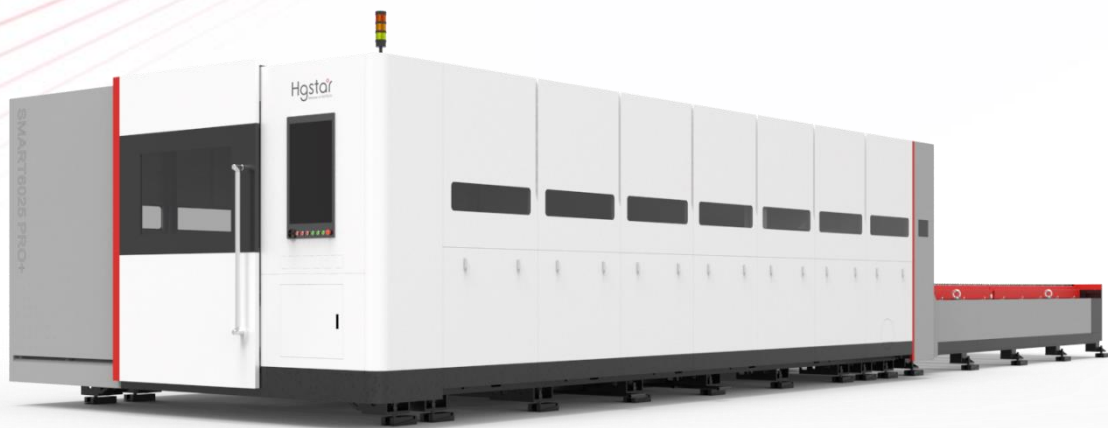

COLAB

**MORE THAN
MACHINES**

Hgstar
Member of HGTECH



SMART SERIES

Laser Cutting Machines

Double Table



MODEL	SMART Pro 3015S
Cutting Area (L×W) / Pracovná plocha	3050mm x 1500mm
Laser Source / Výkon zdroja	Fiber & 1000W – 6000W
CNC System / Riadiaci systém	FSCUT
Rapid Movement / Rýchlo posuv	30m/min, Acceleration is 1.0G
Position Accuracy (X and Y axis) / Pozičná presnosť	0.05mm
Reposition Accuracy (X and Y axis) / Pozičná presnosť	0.03mm
Power Supply Requirement / Požiadavky pripojenia	380V 50/60Hz



Details Beam

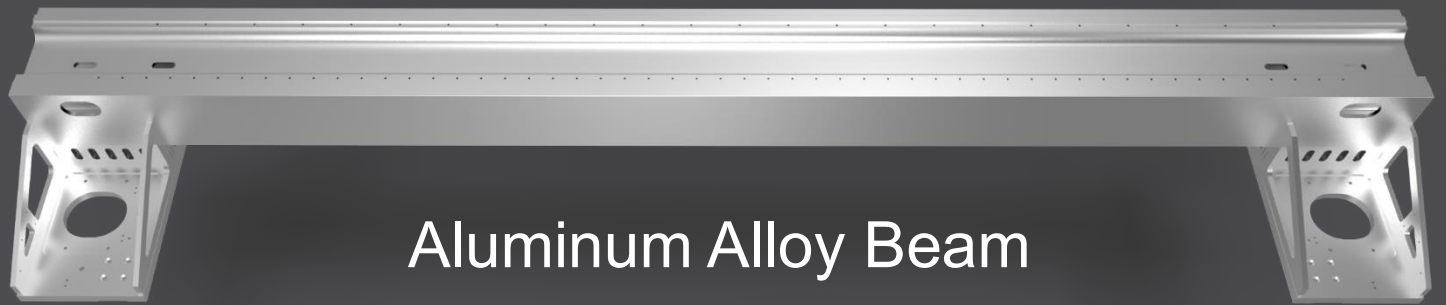
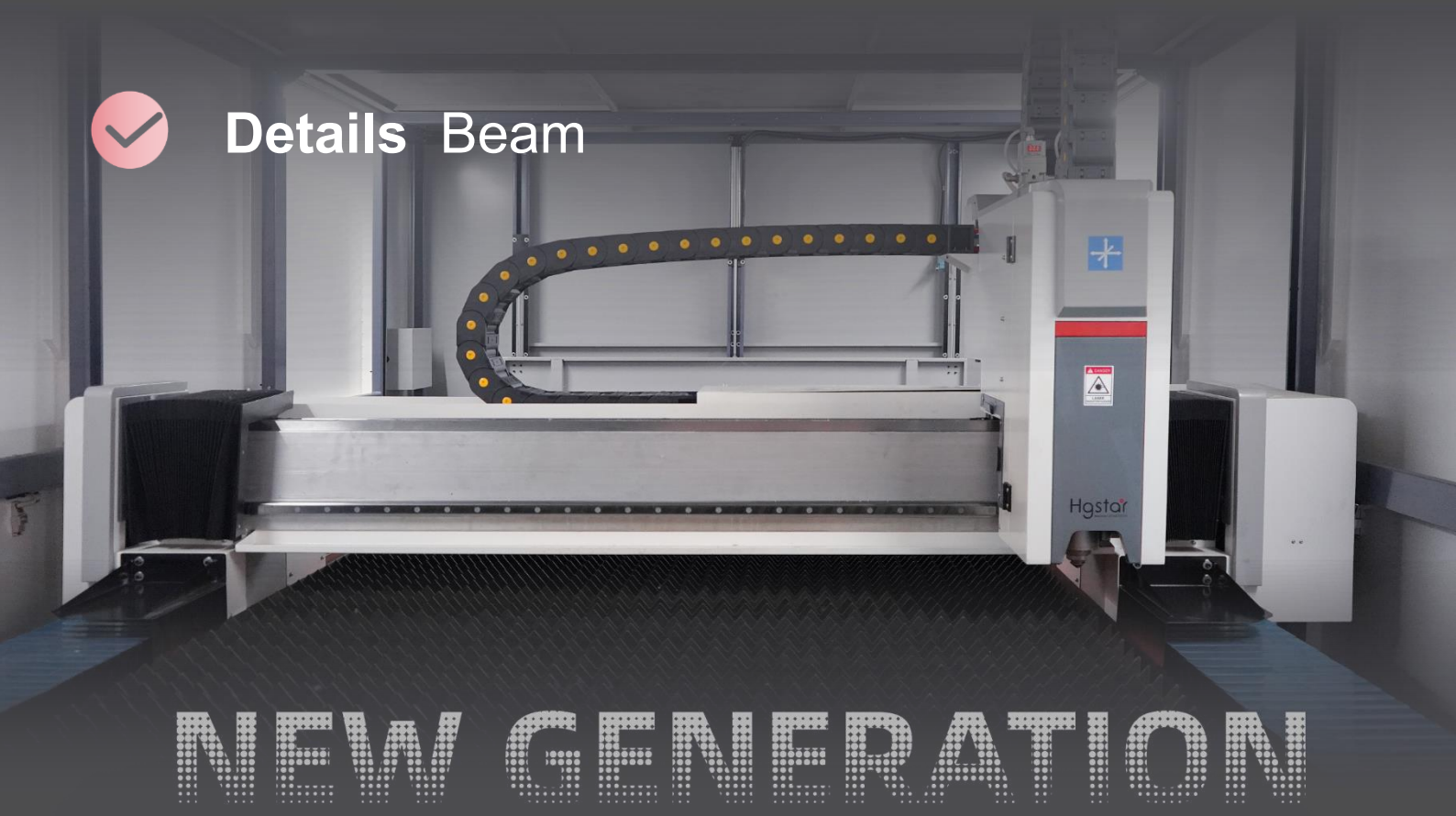

Aluminum Alloy Beam

Aviation aluminum has many advantages, such as good toughness, light weight, corrosion resistance, anti-oxidation, low density, and greatly increase the processing speed.

Hliníkový portál má mnoho výhod, Výborná húževnatosť, nízka hmotnosť, odolnosť proti korózii a výrazne zvyšuje rýchlosť.



The light crossbeam can ensure the machine have high moving speed and improve the processing efficiency.



Details Machine bed

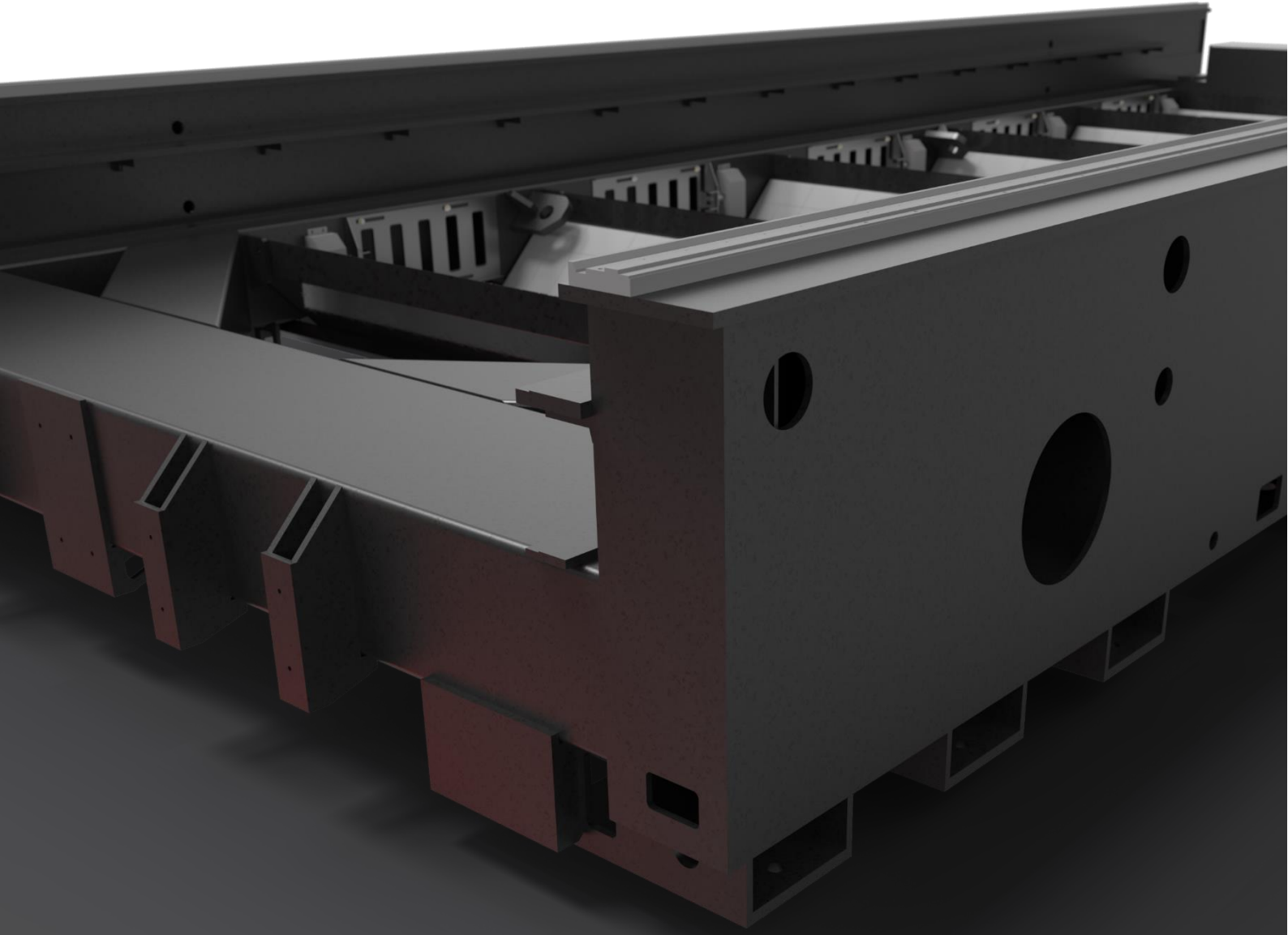

Heavy duty welded bed

It is welded by heavy steel plate, the current mainstream bed structure, high stability. The plate welding bed is subjected to stress relief annealing treatment on the basis of heavier, so that the bed is not easy to deform.

Konštrukcia stroja je zvarená, zbavená vnútorných napätí a následne opracovaná. Poskytuje výbornú dlhodobú stabilitu a dopomáha ku kvalitnému a stabilnému reznému procesu



Details Laser source / Laserové zdroje

OPTIONAL



Higher photoelectric conversion efficiency

V ponuke máme tri základné laserové zdroje :

Max
Raycus
Reci

Pre náročnejších klientov ponúkame aj zdroje IPG

6000W
4000W
3000W
2000W
1500W
1000W



Details Structure

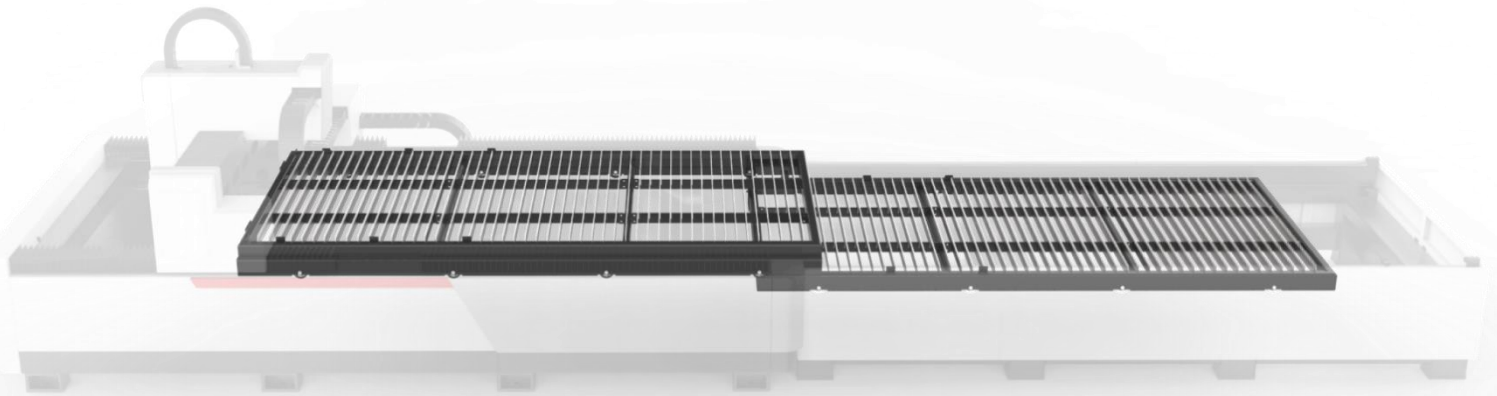

High-speed parallel exchange platform design

Paralelne výmenné stoly zaručujú rýchlu a stabilnú výmenu obrobkov

Security and non-pollution

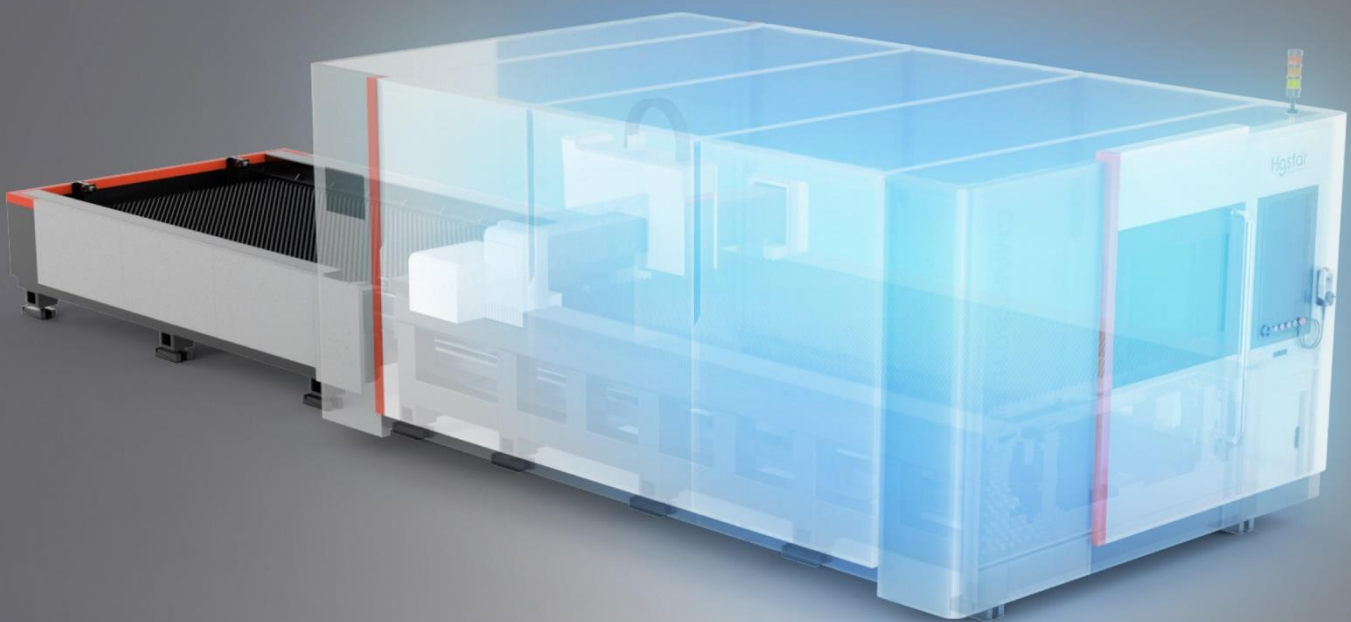

Plne uzavretý priestor rezania, zaručuje čisté a bezpečné prostredie pre pracovníkov. Zakrytie vrátane priezoru na pozorovanie spĺňa Európske predpisy bezpečnosti.



Details

Partition dust removal

Inteligentný riadiaci systém ovláda klapky odsávania, čo zvyšuje účinnosť odsávacej jednotky. Šetrí energiu a zaručuje čistotu rezného procesu.

open

closed



Details

Automatic lubrication system

Automatický domazávací systém, sa postará o včasné mazanie pohyblivých častí stroja. Správne mazanie zabezpečí správne fungovanie stroja a predĺži životnosť vášho stroja



Klimatizovaná
radiaca
jednotka



Machine Model	SMART Pro
Cutting Area (L×W) / Pracovná plocha	3048mm×1524mm
Laser Source / Laserový zdroj	Raycus Fiber & 1000 - 6000W
Transmission system / Typ pohonu	Dual sides driven gantry structure / Portál hnaný dvoma motormi
CNC System / Riadiaci systém	FSCUT 4000E
Servo Motor / Motorizácia	Yaskawa (JAPAN)
Laser Cutting Head / Rezacía hlava	Raytools BM111 / BM06K
Display / Obrazovka	27" Industry LCD
Max Moving Speed / Rýchlo posuv	120m/min, Acceleration is 1.2G
Position Accuracy (X and Y axis) / Pozičná presnosť X	0.05mm
Reposition Accuracy (X and Y axis) / Pozičná presnosť Y	0.03mm
Lubrication system / Mazanie	Full-automatic
Power Supply Requirement / Pripojenie	380V 50/60Hz
Max loading (KG) / Nosnosť stola	1000 KG
Machine weight / Váha stroja	≤7000 Kg
Appearance size / Rozmery	9000mm×3500mm×2306mm
Working environment / Pracovné prostredie	Temp:5- 35 °C, humidity:≤70%



Details Machine configuration

NO.	Model	Name	Quantity	Remarks
1	SMART SF	Fiber laser cutting machine (3048mm*1524mm)	1 set	HGSTAR
2	1000 – 6000 W	Laser generator	1 set	RAYCUS
3	Water chiller	Special water chiller for fiber laser generator	1 set	HANLI 3000W / 6000W
4	Laser head	High accuracy professional fiber laser head	1 set	Swiss Brand Raytools Auto Focus BM111 / BM06K
5	Control system	FSCUT2000C	1 set	FSCUT2000C / FSCUT4000 E
6	Software	CYPCUT	1 set	CYPCUT
7	Driving system	High speed servo motor	4 set	Japan Yaskawa servo motor X axis 850w Y axis 1300w, Z axis 400w
8	Reducer	imported	4 set	Motovario Franch
9	Electric components	imported	1 set	Chint/Schneider
10	Guide rail	imported	1 set	APEK
11	Rack	imported	1 set	T-win Taiwan



Details Rozmery stroja

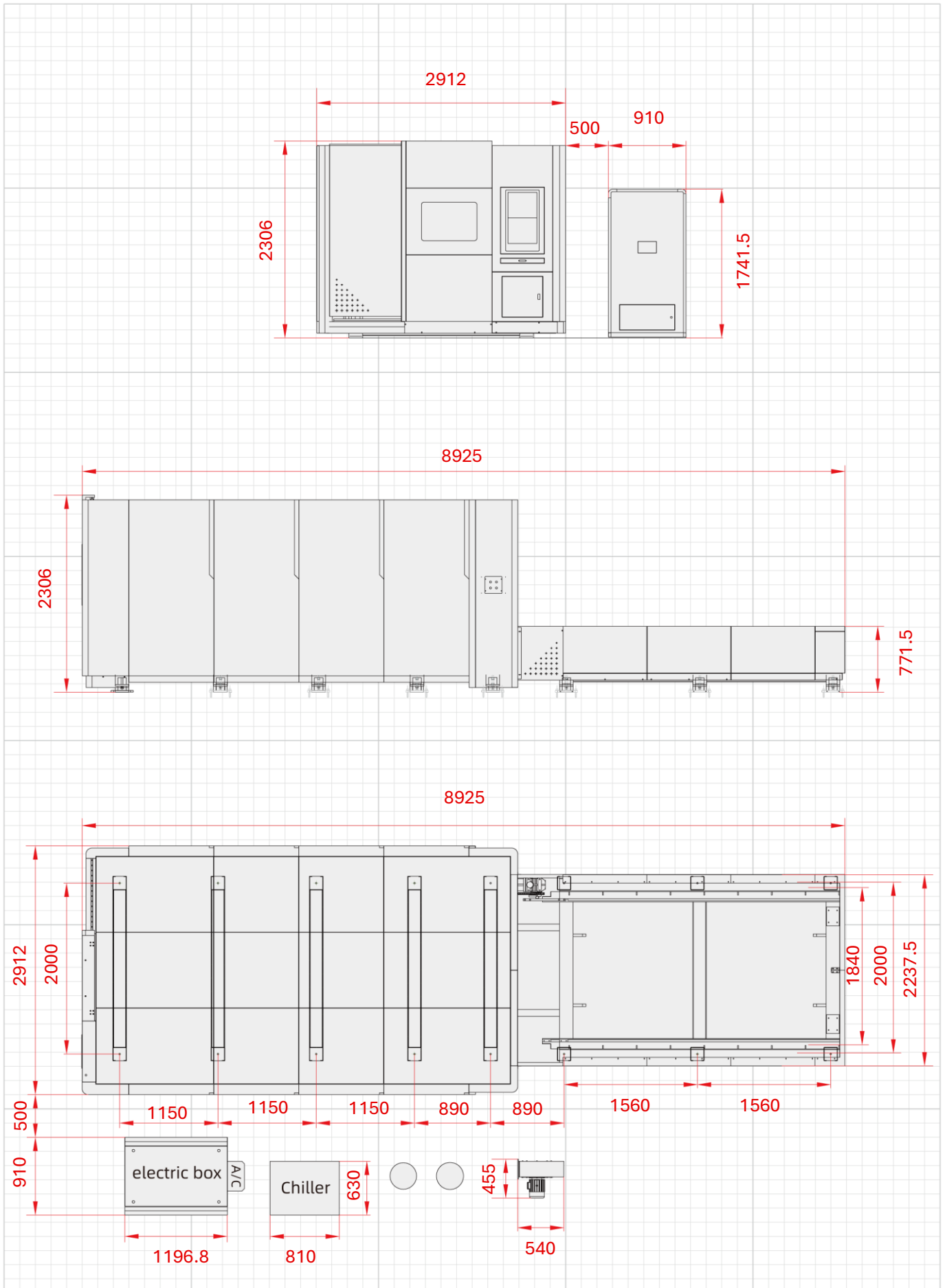



Ability Excellent function / Inteligentné funkcie

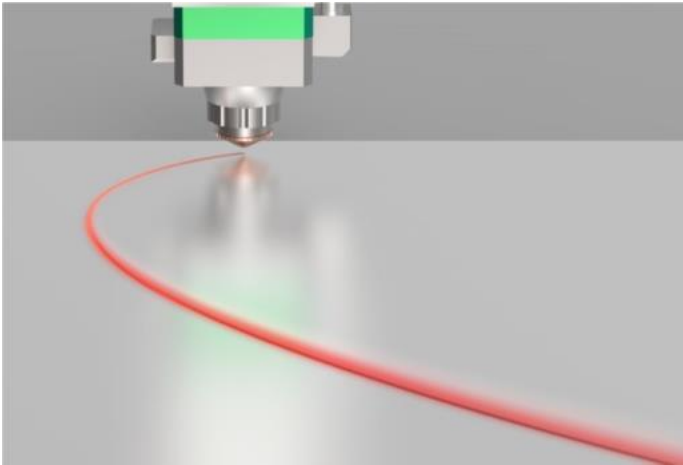

Vibration Suppression

One key quick setting can easily solve the vibration problem of thick plate processing

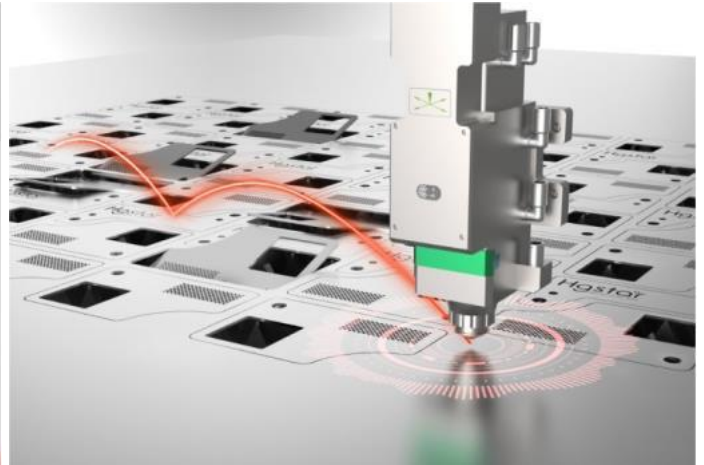

Intelligent obstacle avoidance

Intelligently avoid random raised areas in the cutting process and reduce the risk of head collision



Exclusive tuning database

All you need to do is a simple touch, and the complicated operations are handed over to us

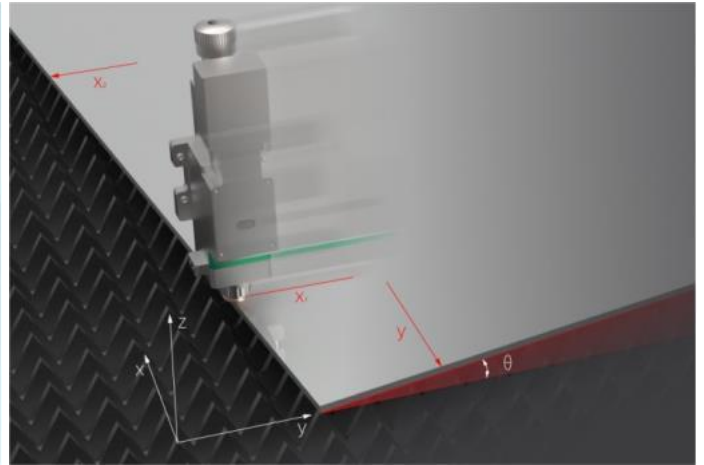

Three point edge finding

The inclination angle and origin of sheet metal are sensed through automatic edge-finding to avoid waste and save time

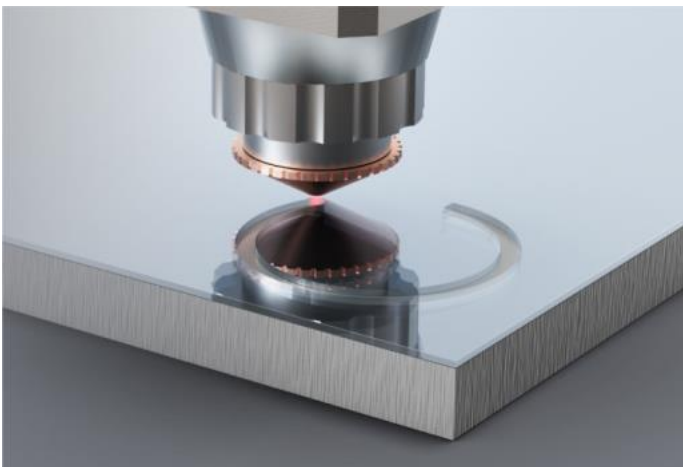

Membrane removal process

The sequence of film removal and pre perforation can be set flexibly and make workpiece cutting more perfect

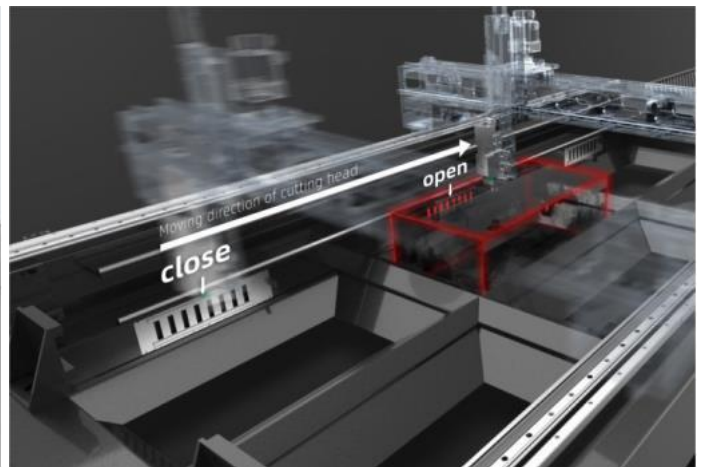

Partition dust removal

Through fine setting, the dust removal tyure can be opened and closed with the movement of the cutting head. Under the same fan configuration, the dust removal effect is effectively enhanced



Hgstar

Member of HGTECH

Hgstar is one of the members of HGTECH Group who is the world second provider of intelligent manufacturing system solutions with laser intelligent equipment as the core and whole industry chain layout. We has accumulated 50 years of industry technical experience since 1971.



50

years

SINCE
1971



Innovation Fuels a Better World



COLAB

**MORE THAN
MACHINES**

Colab a.s. oficiálny distribútor pre
Slovenskú republiku, Českú
republiku a Maďarsko.

Sídlo a showroom spoločnosti

Coburgová 9813, Trnava

Fakturačné údaje

IČO : 36725099
DIČ : 2022319376

